

Assembly Instructions for the EyeCom 8240
Universal 16/35mm roll film Attachment with the
Micro Image Capture imaging product

The unassembled parts of the attachment are shown below.
-1 each left side and right side assemblies – 16mm and 35mm
take up reels. And the Micro Image Capture unit. A standard #2
Phillips screwdriver is the only tool required for the assembly
process. .

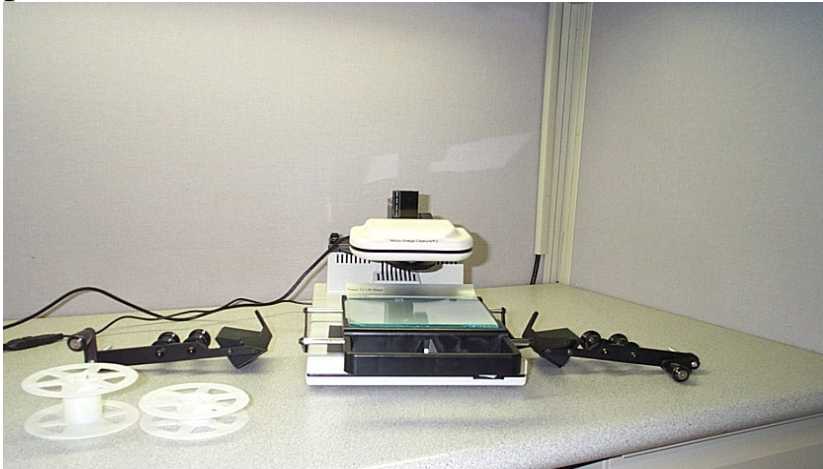

Step 1

Remove the 2 screws from the side of the carrier. Do not remove
the fiche carrier

Figure 1

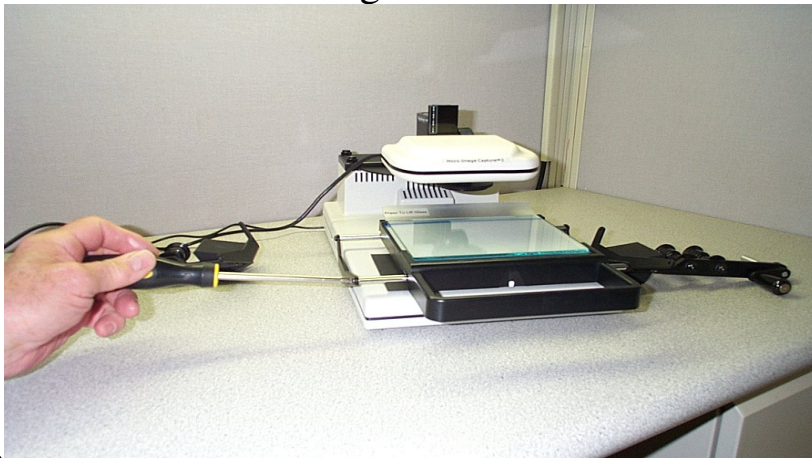

NOTE: Remove the 2 screws from one side and complete the
following step before working on the other side.

Step 2

Using the same 2 screws, attach the arm with the crank handle side facing you as shown in Figure 2 - with the spindle pointing towards the rear. Tighten the 2 screws securely.

Figure 2

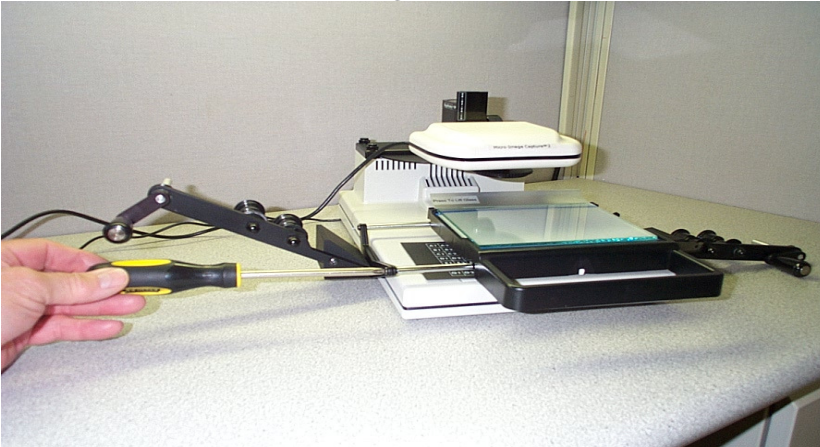

Step 3

Perform the same assembly process with the other side- - remove the 2 screws place the other arm assembly in place and secure it with the 2 screws – tighten the screws and it is recommended to check the other side's screws to make certain they are secure.

Figure 3



Operation of the Roll film Attachment

The completed assembly is shown above in Figure 3. Film may be wound coming off the left side reel in a clockwise manner- but an anti-clockwise installation can also be acceptable. In either case, be certain to thread the film coming off the top of the roller closest to the base of the imager to minimize the possibility of damage to the film.

Additional instructions for viewing microfilm and microfiche

The imager electronics can be used to electronically turn the image right side up or reverse the image from mirror image to right reading.

Film can either be transported between the glasses or it can be positioned on top of the upper glass.

NOTE: The attachment is designed be left on the unit permanently. When viewing microfiche simply push on the upper carrier at the rear- see the noted label- simply press to open the carrier glass for threading the film through the glasses or for insertion of microfilm or microfiche.

The parts description of the attachment is as shown. Please contact your selling dealer should replacement parts be required.

2. Film Idler assembly
3. Idler shaft
4. retaining Ring type "E"
5. roll film arm
6. Spindle assembly
7. handle assembly
8. Internal tooth lockwasher
9. 10-32 cap nut
10. Setscrew 4-40

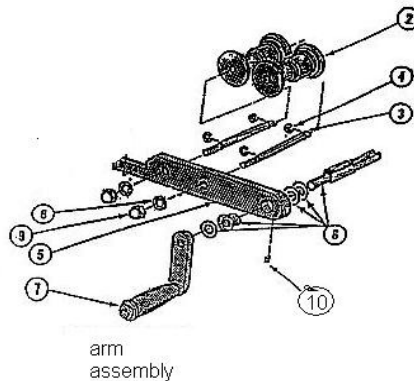

Eye Communication Systems Inc.

455 E Industrial Drive

Hartland Wisconsin 53029 0620 United States of America

1-800 558-2153 toll free- 001-262-367-1360

V Oct 2011